

LabScat

Laboratory Turbidity Meter



Applications

- Laboratory turbidity measurement in bottles or cuvettes
- Verification of online measuring instruments
- Accelerated aging test in the bottle

Industries

- Beverage (beer, spirits, wine, soft drinks)
- Food
- Chemical industry
- Pharmaceutical industry

Advantages

- Compact design
- High measuring span
- Precise and reliable measurement also at 0 °C / +32 °F
- Colour-compensated dual-angle measurement according to MEBAK-Standard
- Bottle rotation and water bath to minimize interfering influences
- Monitoring of the water bath quality
- Integrated operation panel with colour touch screen display
- Quick verification with secondary standard
- Minimum maintenance, no tools required

Innovations with tangible benefits



Compact design

The design of the instrument is very compact. All relevant parts are accessible without tools.

A valve unit allows complete draining the water bath:

- Minimum lab bench space required.
- All popular bottles can be measured.



Convincing measuring technique

High quality optical components combined with well proven dual-beam measurement technique result in extremely low stray light characteristics. The bottle or cuvette is centred before the measurement starts and rotated in the water bath during measuring:

- Stable measurement of a few mEBC up to 500 EBC (e.g. for dark wheat beer) are possible also at low temperatures 0 °C/+32 °F.
- Interfering influences of the bottles are reduced, resulting in more precise measurement.
- Contaminations on the windows and the influence of colour from the bottle and medium are automatically compensated.

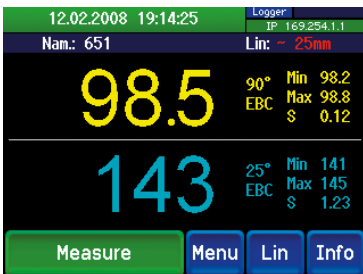

Intuitive operation

Integrated operation panel with touch screen and colour display:

- Simple and clear operation.
- Extensive communication possibilities including integrated web browser.
- Password protection prevents unwanted access.



User-friendly maintenance

The quality of the water bath is monitored, if necessary, an alarm is triggered. The bottle drive can be removed out of the water bath without the need of tools. A solid reference standard is available for quality assurance:

- The little required maintenance is easily performed.
- Exact verification and, if necessary recalibration without the need of Formazine is possible.
- Low total cost of ownership.

Your representative:



photometer.com/8734

Technical data

Measuring principle:	Scattered light 90°/25°
Wavelength:	LED 650 nm
Measuring span:	0 .. 200 EBC (standard calibration) 0 .. 500 EBC (with special cuvette)
Measuring units:	EBC, ASBC, FTU, NTU
Resolution:	0.001 EBC
Measuring time:	12 seconds
Bottle dimensions:	Ø 50 .. 88 mm up to 330 mm height
Water bath temperature:	0 .. +40 °C/+32 .. +104 °F
Ambient temperature:	0 .. +40 °C/+32 .. +104 °F
Ambient humidity:	0 .. 99 % RH
Power supply:	12 VDC via separate power supply (included with delivery) 100 .. 200 VAC 47/63 Hz
Power consumption max.:	10 W
Weight:	5 kg
Recalibration:	Secondary solid reference
Operation:	
Display:	1/4 VGA, 3.5"
Operation panel:	Touchscreen
Digital Interface:	Ethernet, USB
Sample identification:	Web browser
Data transfer:	Web browser, USB
Optional:	
Temperature control:	Automatic measurement in open special cuvette

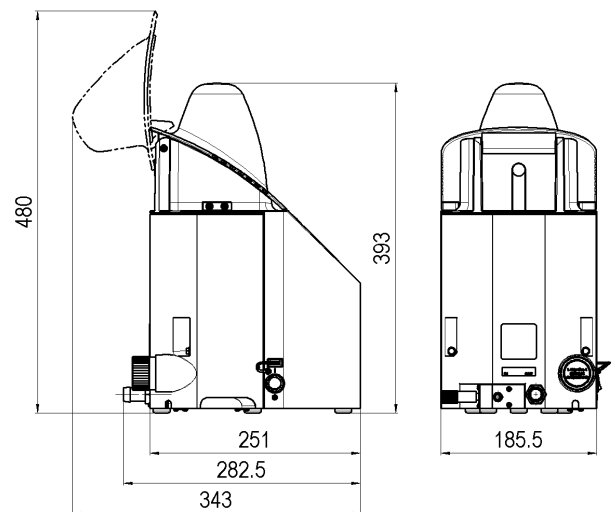

SIGRIST
PROCESS-PHOTOMETER

SIGRIST-PHOTOMETER AG

Hofurlistrasse 1 · CH-6373 Ennetbürgen
Tel. +41 41 624 54 54 · Fax +41 41 624 54 55
www.photometer.com · info@photometer.com